

SCALEMIN HT

Rock scaler



Scalemin HT is a hydraulic diesel scaler machine for underground mining, with a 9 m maximum height.

Electricity is not required for operation.

It has a telescopic arm, equipped with a SB 202T / SC 28 hydraulic rock breaker special for rock scaler, easy maintenance and durable parts.

Chassis for heavy duty, articulated 4WD, self propelled with diesel engine, with central articulation and oscillating rear axle.

Also equipped with a FOPS / ROPS Certified A/C enclosed cabin.

SPECIFICATIONS

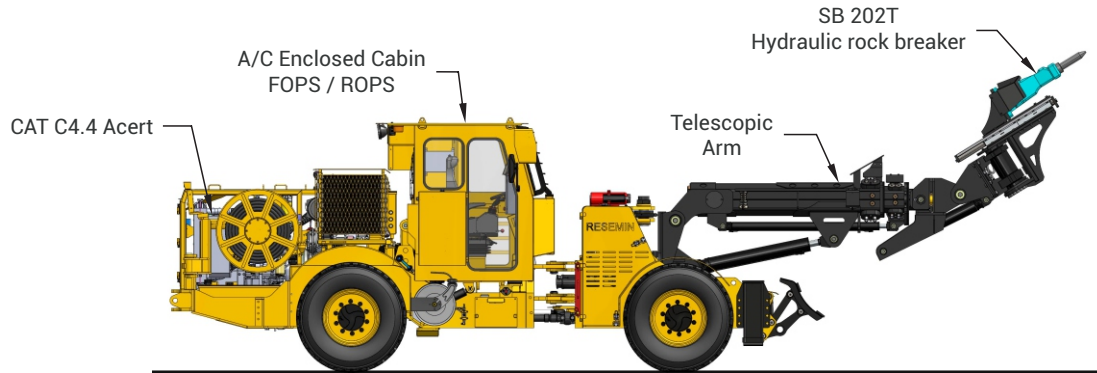

HYDRAULIC ROCK BREAKER

• Model	SB 202T
• Percussion power	13 kW
• Percussion pressure (máx.)	100 - 110 bar
• Frequency	1250 - 1700 bpm
• Air flow range	0.73 m ³ /min
• Air pressure	2 bar
• Oil flow range	40 - 70 l/min
• Weight	200 kg

OPTION

• Model	SC 28
• Percussion power	15 kW
• Percussion pressure (máx.)	120 bar
• Frequency	1420 bpm
• Oil flow range	40 - 75 l/min
• Weight	275 kg

TELESCOPIC ARM

• Model	ST7.4
• Lift angle	-8° / +60°
• Swing angle	±35°
• Arm extension (1)	1550 mm
• Arm extension (2)	1400 mm
• Max. vertical reach	9.08 m
• Max. horizontal reach	8.14 m
• Swing (SB 202T)	120°
• Tilt (SB 202T)	101°

HYDRAULIC CONTROL SYSTEM

• Electric / manual control valve	Parker
• Drilling control	ECS (Electric Control System)
• Percussion pump (compensated pressure)	Rexroth A10V071
• Working pressure	180 bar
• Hydraulic oil tank	43.5 gal / 165 l
• Hydraulic return filter	Parker, 10μ
• Hydraulic high filter	Parker, 10μ
• Tropical cooler	
• Saturation hydraulic filter indicator	Parker
• Indicator of low oil	Hydac
• Indicator temperature oil	Hydac

CARRIER

• Model	D57.X2
• Diesel engine	Caterpillar C4.4 ACERT, Tier 3
- Power	106 kW @ 2200 rpm
• Transmission	Hydrodynamics
• Powershift gearbox	Dana, T20000
• Differential axle	Dana, Series 113
• Rear axle oscillating	± 8°
• Trimming speed:	
- Horizontal	max. 16 km/h
- Positive ramp 15%	max. 7 km/h
• Service brakes	Wet discs
• Emergency and parking brakes	SAHR (Spring Applied Hydraulic Release)
• Steering (articulated carrier)	±40°
• Tyres	12 x R20
• Hydraulic jack	2 extendable front
• Operator Cabin	A/C Enclosed cabin
	360° Video camera
	FOPS / ROPS certification
	inclination 20°
	25 gal / 95 l
	2x12 V, 95 Ah
	24 VDC
	8X, LED 28W, 9-32 VDC
	ANSUL, 4 nozzles
	1x20 lb (PQS)
	Manual
	Manual
	Dozer

• Fuel tank	25 gal / 95 l
• Battery	2x12 V, 95 Ah
• Electric system	24 VDC
• Trimming lights	8X, LED 28W, 9-32 VDC
• Automatic fire suppression system	ANSUL, 4 nozzles
• Fire extinguisher	1x20 lb (PQS)
• High-pressure washing system	Manual
• Reel grease gun	Manual
• Front shovel	Dozer

WATER AND AIR SYSTEM

• Compressor	LE 3-10V
• Maximum capacity	5.1 l/s (10.8 cfm)
• Working pressure	10 bar
• Water pump with hydraulic motor	Grundfos, CR1 - 6
• Maximum flow	2.18 m ³ /h (36 l/m)@3480rpm
• Minimum inlet pressure	2 bar
• Water tank	100 l

OPTIONAL

• Wireless Remote Control	To control Scaling process
---------------------------	----------------------------

DIMENSIONS

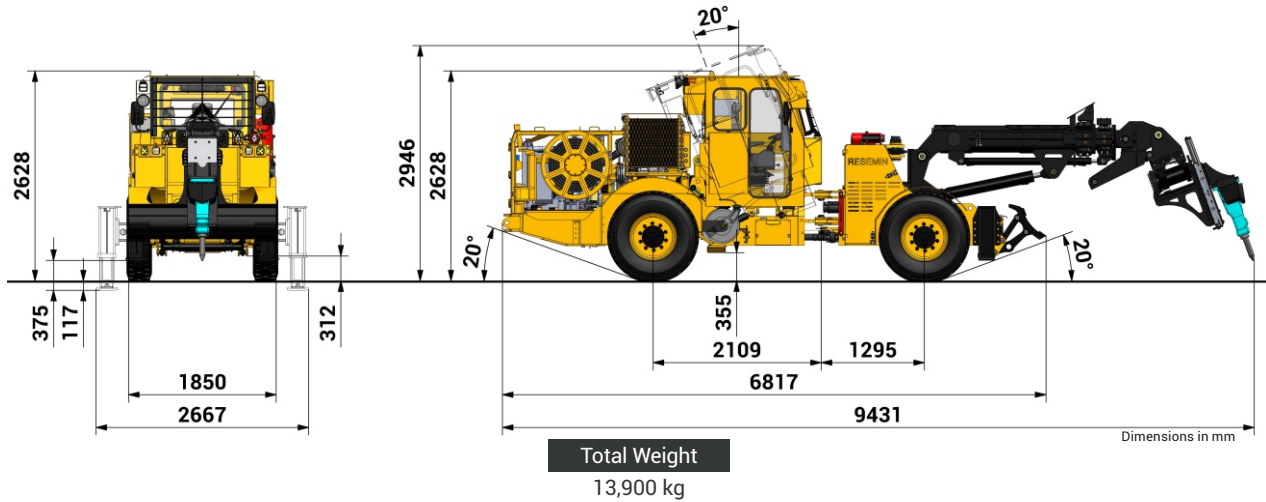

TURNING RADIUS

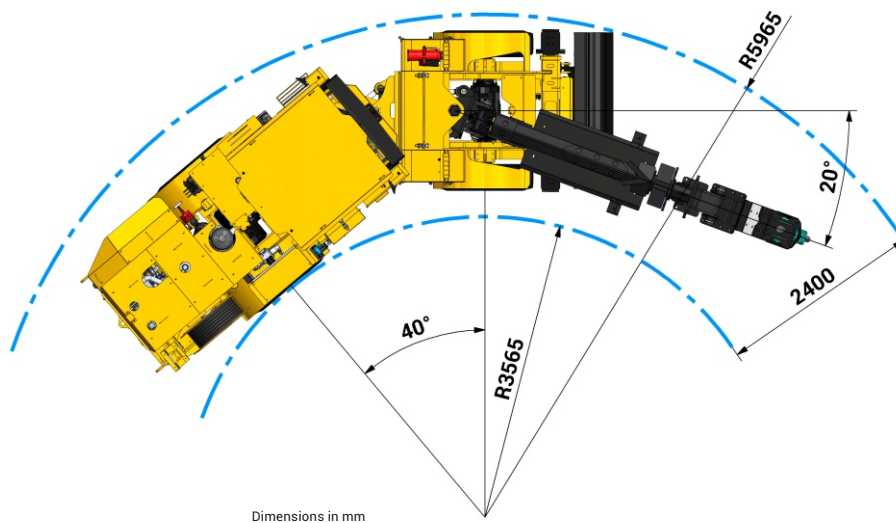

COVERAGE

